

Electric Power System Design of PEFP to Ensure Reliability in Operation

Apr. 13, 2010

Kyeong-Jun Mun

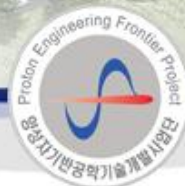

양성자기반공학기술개발사업단
Proton Engineering Frontier Project
<http://www.komac.re.kr>



Contents

- I . Introduction**
- II . Electrical Power System of PEFP**
- III . Monitoring & Control of Electrical Power System of PEFP**
- IV . Conclusions**



- When faults occur in electric power systems, impact of outages should be minimized and the faulted facilities should be restored as soon as possible.
- This requires that an operator in the control center should find the reason and the location of the faults by analyzing the alarm information of protective relays or circuit breakers.
- Based on the alarm information in electric power system, we designed the proper monitoring & control system for the electric power system of PEFP.

□ Electrical Power System of PEFP



Proton Accelerator Research Center of PEPF

Geoncheon Substation

(154kV Substation)



Power Supply Building



Overview of the Electrical System

■ Electric Power System In 100MeV Proton Accelerator Conventional Facilities

- Electric power is supplied by 154kV substation, 154/3.3kV step-down transformers.

• Power Distribution System

– normal power system

- ① 3.3kV Switchgear
- ② 480, 220V Load Center
- ③ 480V MCC (Motor Control Center)

– Emergency Power system

- ① UPS (uninterruptible power supply) & DC System)
- ② emergency diesel generator

Electrical System Component

Flow Diagram of the Electric Power System of PEFP

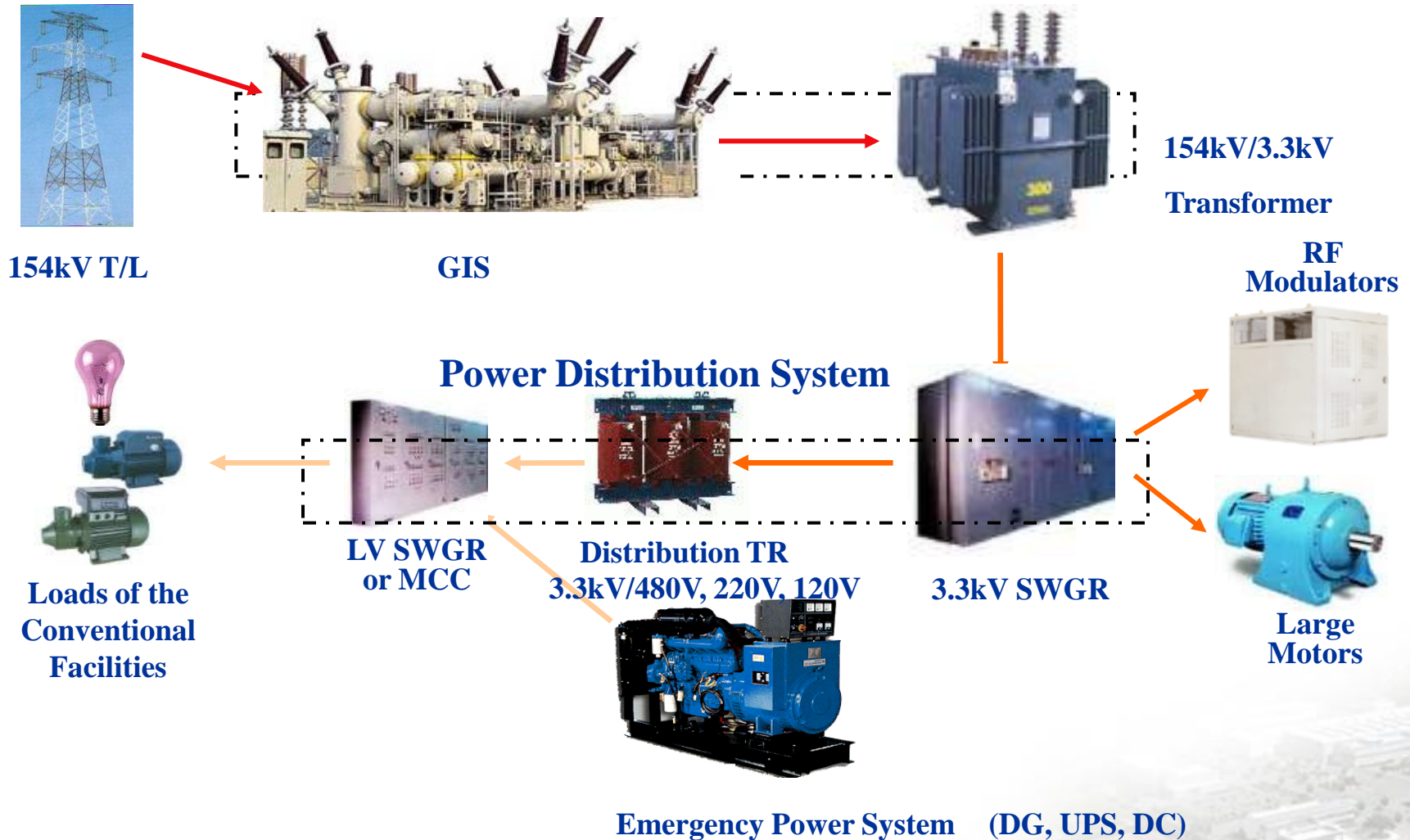

Electric Power System Configuration of PEFP

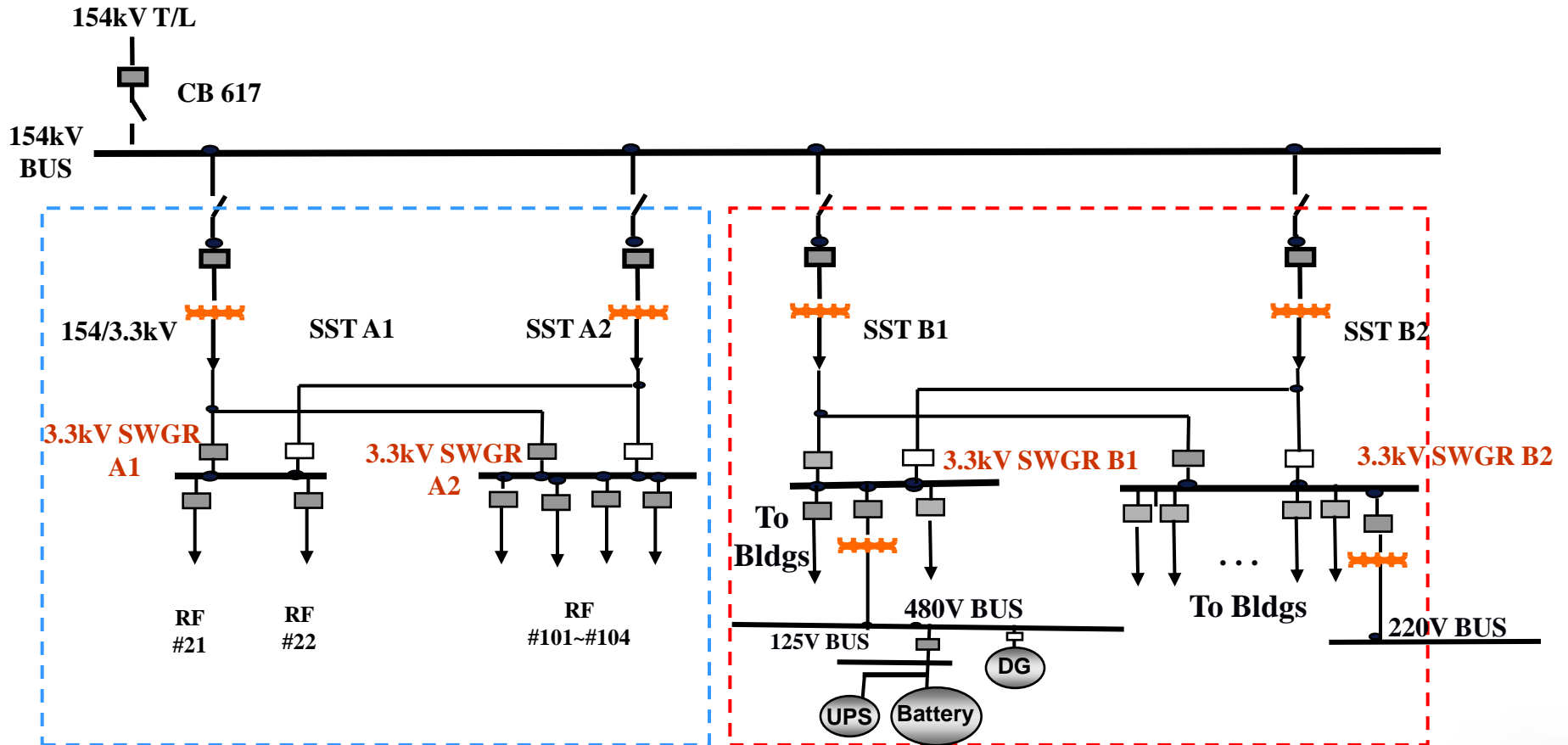

System A : RF System

System B : Conventional Facilities System

Functions of the 154kV Substation Facilities

- It receives power through the one 154kV overhead transmission line from the 154kV substation.
- It is located near the proton accelerator facility and supplies electrical power to the accelerator conventional facility via 154/3.3kV step down transformer.
- Also the system includes control, monitoring and protection facilities.

□ Major Equipments

- **Single 154kV Bus**
- **Gas Insulated Switchgear (GIS)**
 - 170kV, 50kA , 1200A (32 MVA)
- **Unit Service Transformers (154/3.3kV)**
 - 5/6.67MVA (ONAN/ONAF) : 2 Banks for RF System
 - 15/20MVA (ONAN/ONAF) : 2 Banks for Conventional Facilities
 - 1 Bank for Normal Operation, 1 Bank for Stand-by

Power Distribution System Configuration of PEFP

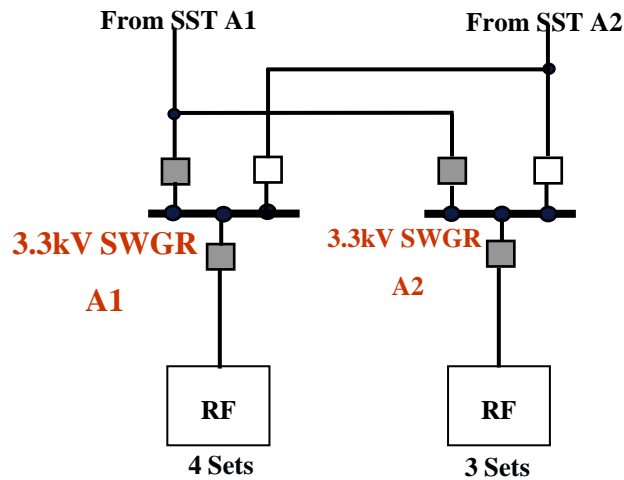

• System A

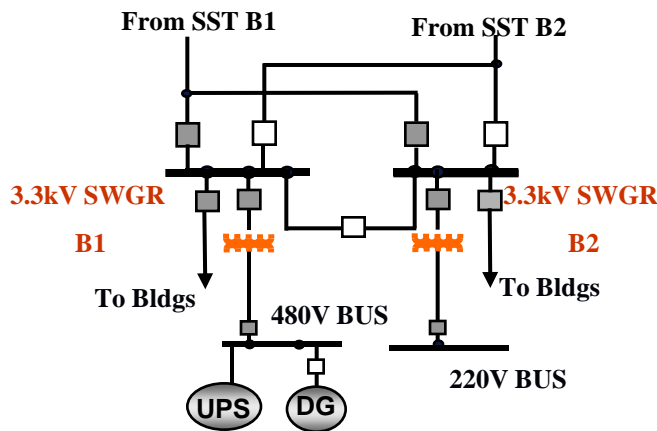

• System B

- Power Distribution System provides electric power to the
 - 1) RF power supply system (System A)
 - 2) Conventional Facilities (System B)
- Power Distribution System consists of :
 - 1) 3.3kV switchgear system
 - 2) 480V & 220V load center system
 - 3) 480V motor control system (MCC)
 - 4) emergency power system (Diesel generator, UPS, DC system)

Power Distribution System Components

□ Major Equipments

• 3.3kV switchgear System

- 2 sets for RF modulators (System A)
- 2 sets for the conventional facilities (System B)
- Use Vacuum circuit breakers
- Large motor loads (≥ 250 Hp) and distribution TRs are powered from 3.3kV Switchgears.

• 480V & 220V Load Center System

- 3 phase, 3.3kV/480V, 3.3kV/220V delta-*wye* connection
- 480V emergency load center with emergency diesel generator.
- It supplies power to
 - 1) 480V rated load
 - 2) 100kW ~ 400kW non-motor load
 - 3) 480V MCC
- 3.3kV/220V load center transformer supplies power to 220V rated load such as test facilities.

• 480V Motor Control Center System

- | | |
|----------------------------------|-----------------------------|
| – motor (45kW and less) | – Non-motor (75kW and less) |
| – Motor operated valves (MOV) | – Heater |
| – process control | – lighting and receptacle |
| – Heat tracing system | – Moisture resting heater |
| – Cathodic Protection Facilities | |

Emergency Power System Configuration

DC & UPS System

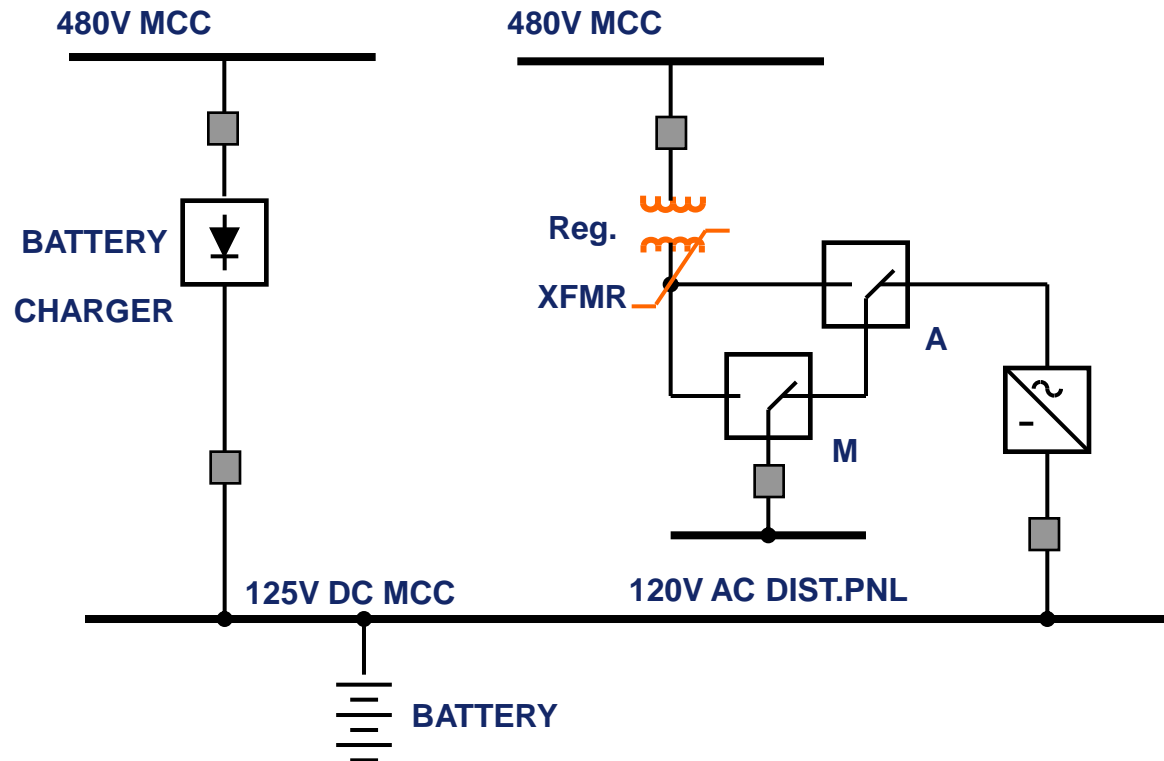

Functions of the Diesel Generator System

- **Function of the Emergency Diesel Generators**
 - Provide Backup Power for Essential Loads during Loss of Offsite Power
 - Automatic Starting and Power Restoring without Interruption

- **Specification of the Emergency Diesel Generators**
 - 3 Phase, 480V, 50~200kW Class
 - Diesel generators can operate for 2000 hours continuously.
 - Diesel generators can operate with overload condition for 2 hours continuously out of 24 consecutive hours without excessive vibration or damage of engine/generator.

- **2 sets will be installed**
 - Accelerator and Beam Application Bldg, Ion Beam Application Bldg, etc
 - Support Buildings (such as Main Office, Regional Cooperation and Dormitory Building)

- **Emergency Diesel Generators will supply power to the following systems :**
 - Access Control System
 - Standby Ventilation Fans for Tunnel/Experimental Hall
 - Emergency Lighting for Tunnel/Experimental Hall
 - Standby Lighting System

DC Power System

● Function of the DC System

- DC power system supplies DC power to the DC loads of the proton accelerator conventional facilities and 120V UPS system.
- AC power supplied from 480V emergency diesel generator bus is transformed to DC power through the battery charge.

● Design Features

- Nominal Voltage : 125V (Operating Range 105~140V)
- 30 Minutes Duty Battery

□ Major Equipments

- Battery : 58 Cells (2.16V/Cell)
- Charger : Full charging capacity within 12 hours
- Distribution Panels

UPS System

- **Function of the UPS System**
 - It provides reliable AC power with constant voltage and frequency.
 - For High Quality and High Reliability Power Required Loads.
ex) the vital control and instrument devices
 - It is provided power from 480V emergency diesel generator bus and from 480V common bus

- **Design Description of the UPS System**
 - 120V AC and 220V AC
 - 30 Minute Duty
 - AVR, Inverter, Battery, and Distribution Panel

- **UPS will supply power to the following systems**
 - Safety Interlock System
 - Vacuum System Instrumentation and Control
 - Critical Power Supply Control and Protection (Relay, CB and Trip)
 - Main Control Room Server and Network Hardware
 - Selected Telecommunication Equipment
 - Selected Alarm System

Power Distribution System

Single Line Diagram of Power Distribution System (3.3kV)

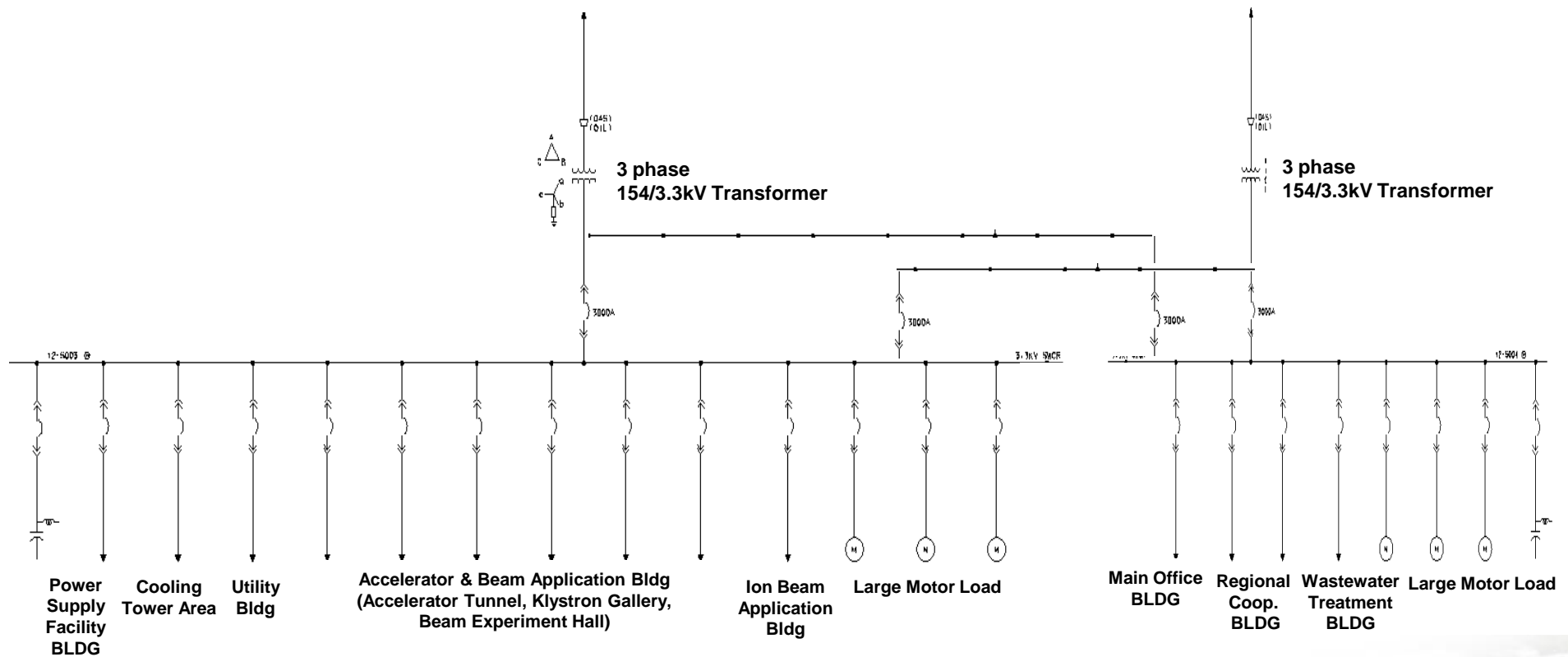

Power Distribution System

Single Line Diagram of Power Distribution System (220V)

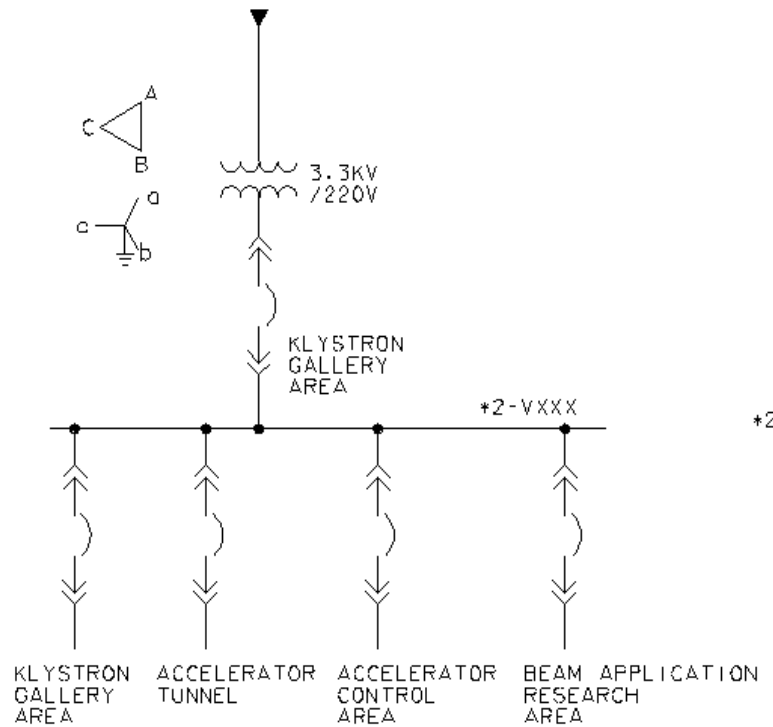

Accelerator & Beam Application Building

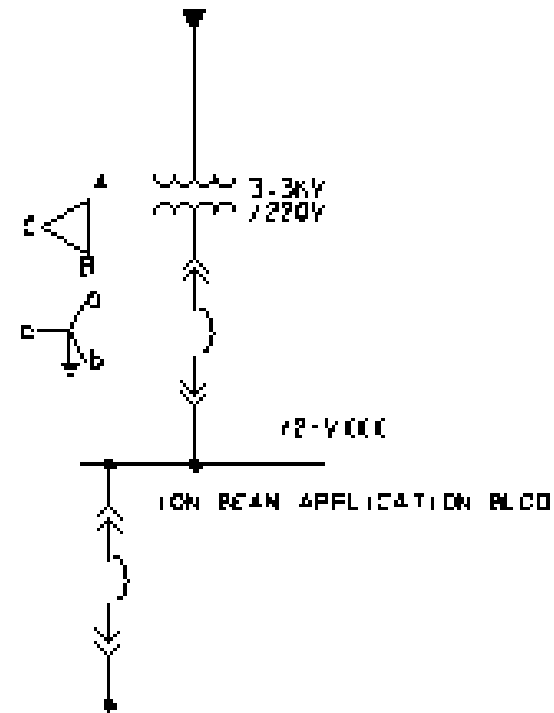

Ion Beam Application Building

□ Monitoring & Control of Electrical Power System of PEFP



Monitoring & Control of Electric Power System

□ Remote Control

- 154kV GIS
 - 1) CB
 - 2) DS
 - 3) Earthing switches
- 3.3kV switchgear
 - 1) Incoming breaker
 - 2) 220 & 480V L/C, 480V MCC
 - 3) TR feeder breaker

□ Remote Monitoring

- 154kV GIS operating status
- Transformer operating status
- 3.3kV SWGR, 480V L/C, 480V MCC and 220V L/C system operating status
- 125V DC, 120V vital AC system operating status

Functions of the Electric Power Protection System

- When a fault occurs on a power system such as buses, lines, transformers, etc., faulted section should be removed promptly.
- If fault is not cleared early, personal injuries and serious damages in electrical facilities can occur.
- To remove faulted section, appropriate circuit breakers are tripped by corresponding protective relays operation.
- Alarm signals warn possible fault unless alarm status cleared.
- Alarm signals , protective relays and circuit breakers for fault conditions are transmitted to the control centers.

Power Distribution System Protection Scheme

Protective Relay for each Power System Component

Protective Relay	Equipment
487 (Differential Relay)	154kV T/L
421 (Distance Relay)	
450 (Overcurrent Relay)	
427 (Undervoltage Relay)	
487 (Differential Relay)	154kV Switchgear
427 (Undervoltage Relay)	
450 (Breaker Failure Protection Relay)	
487A (Differential Relay)	154kV/3.3kV Transformer
450/451 (Overcurrent Relay)	
451N (Neutral Ground overcurrent relay on Transformer primary)	
151N (Neutral Ground overcurrent relay on Transformer secondary)	
63X (Pressure Relay)	3.3kV Switchgear
27 (Undervoltage Relay)	
47 (Phase Sequence Voltage)	
25 (Synchronism Check)	
51 (overcurrent relay)	
51N (Ground Overcurrent Relay)	
51 (Phase Overcurrent Relay)	3.3kV Feeder
51N (Phase Overcurrent Relay)	
51G (Ground Fault)	

Power Distribution System Protection Logic

154kV T/L and Bus Protection Logic

154KV SWYD T/L PROTECTION SYSTEM

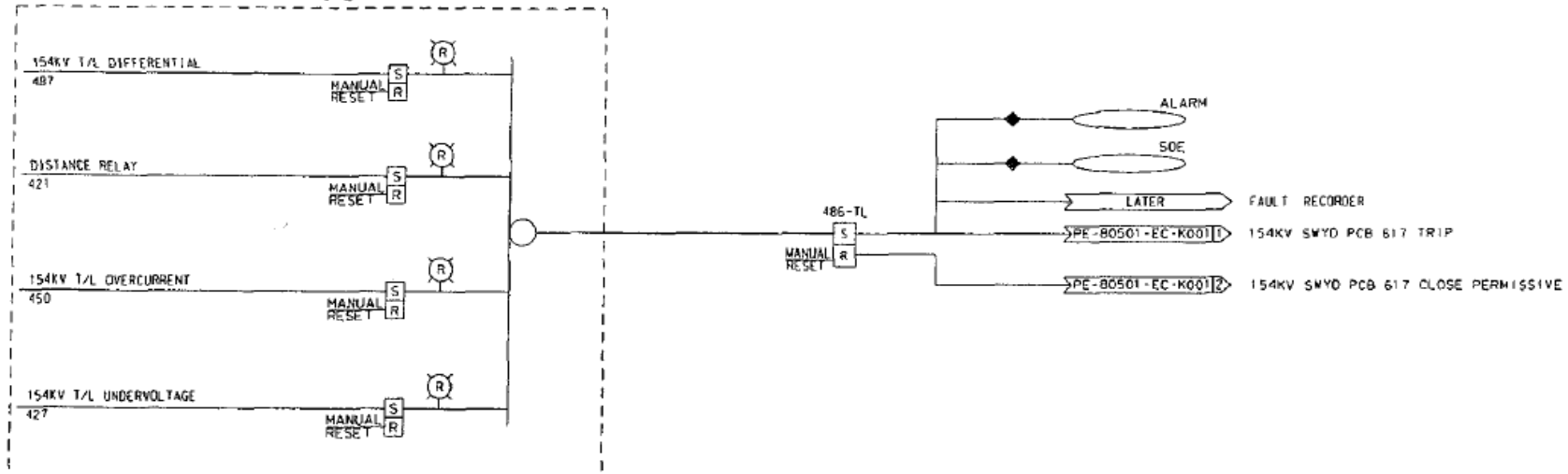

154KV SWYD BUS PROTECTION SYSTEM

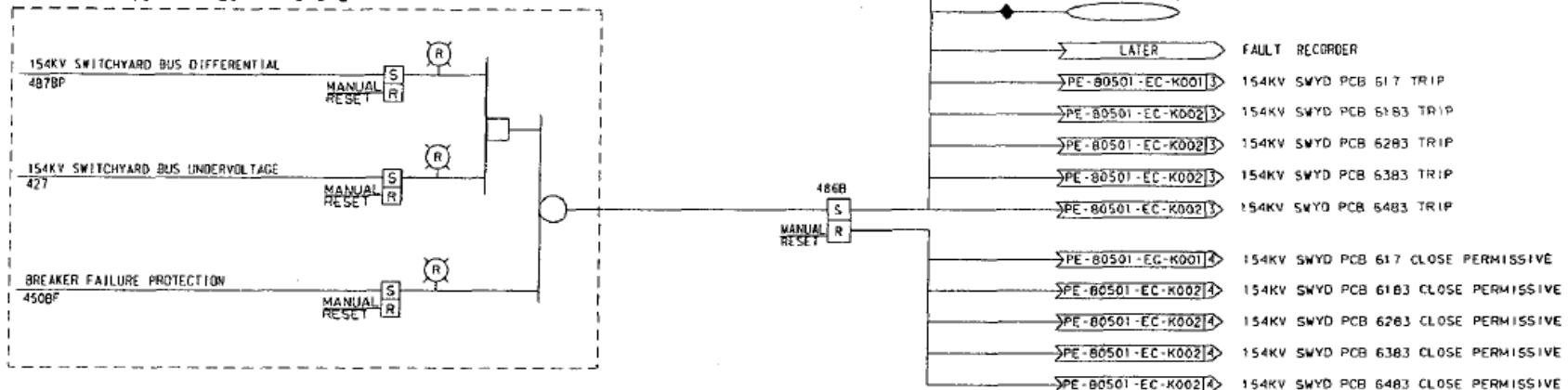

Power Distribution System Protection Logic

154kV/3.3kV Transformer Protection Logic

XFMR TR01 PROTECTION SYSTEM

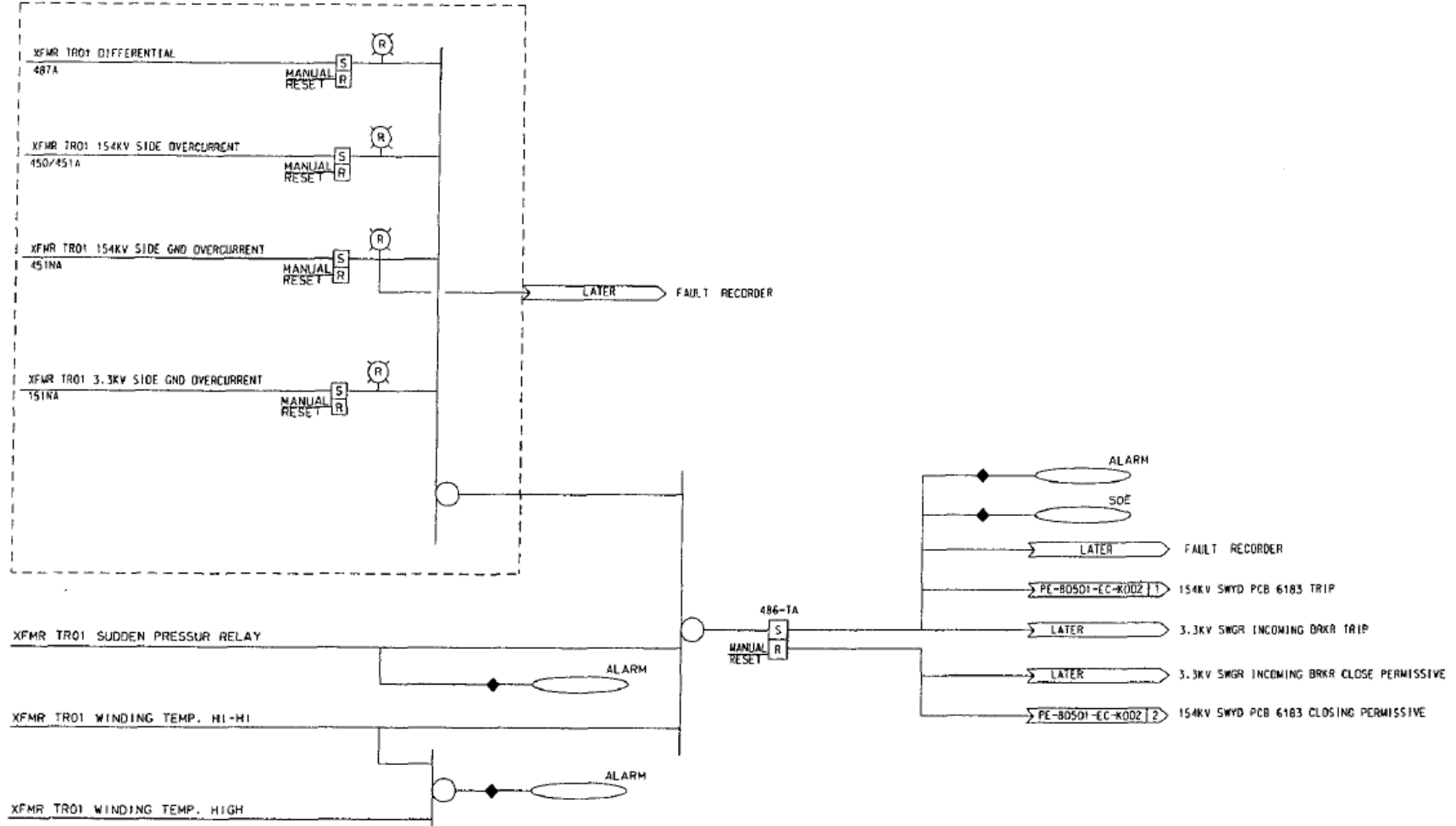

Emergency Power System Protection Scheme

Protective Relay for each Power System Component

Protective Relay	Equipment
DG rated voltage & frequency	Emergency Diesel Generator
51 (Phase Overcurrent)	
64 (DC bus ground)	UPS & DC System
72 (Incoming Battery Charger Breaker Open/Trip)	
72 (Battery Charger Incoming/Output Breaker Open/Trip)	
37 (Battery Charger DC Output Failure)	
27 (Battery Charger Low DC Voltage)	
59 (Battery Charger High DC Voltage)	
27 (DC bus undervoltage)	



Emergency Power System Protection Logic

Diesel Generator Protection

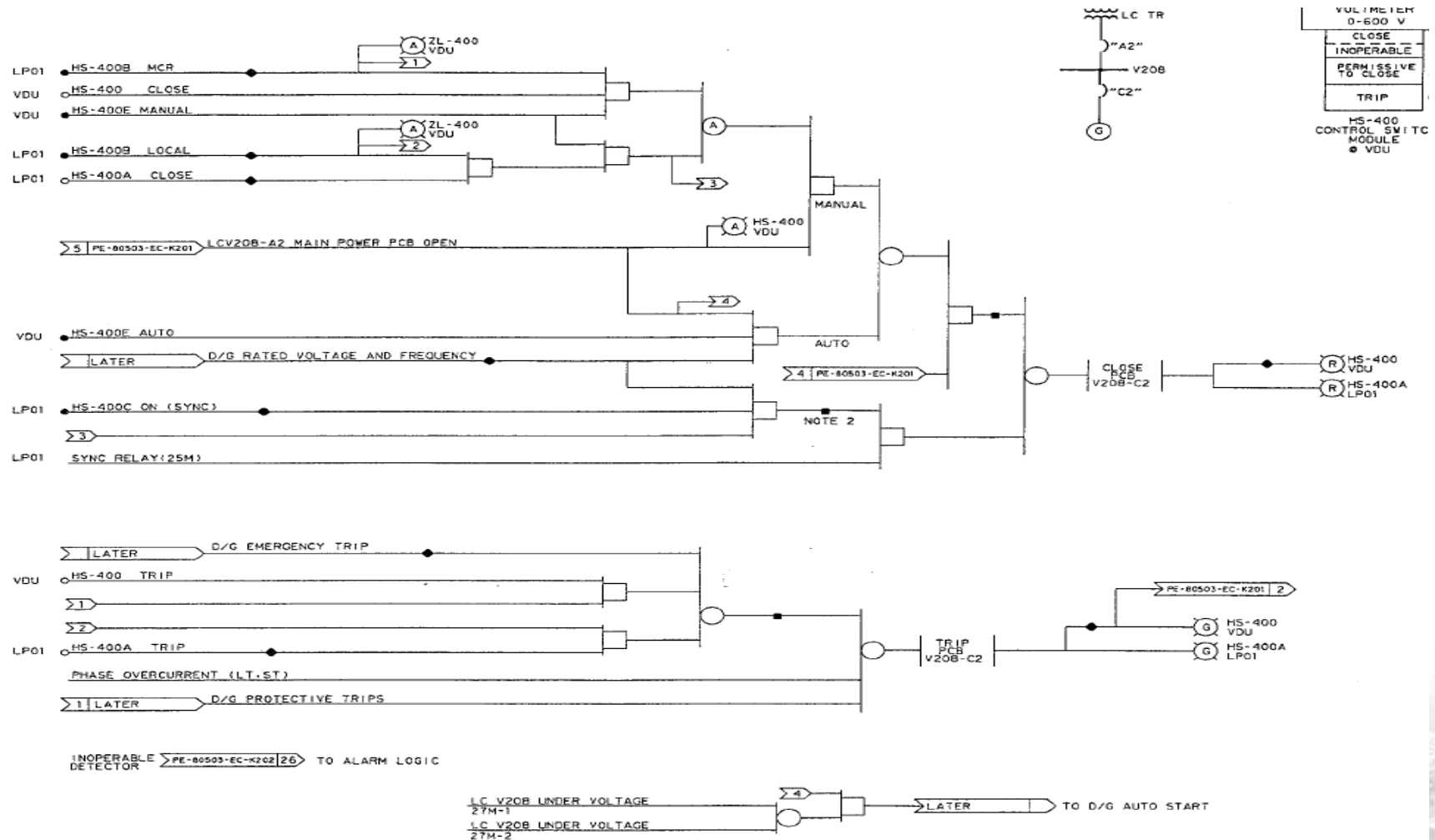

Emergency Power System Protection Logic

DC & UPS Protection

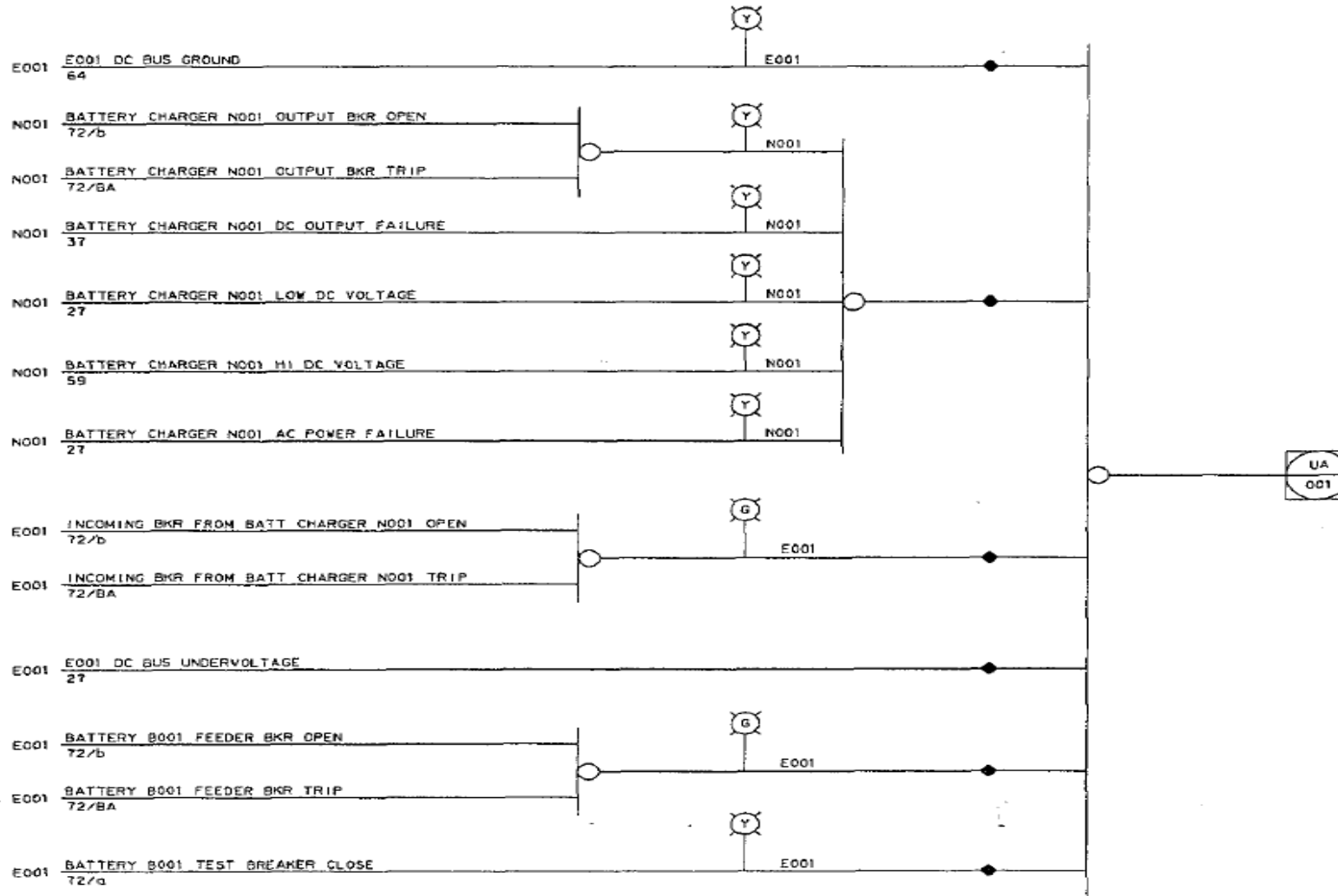

■ Electric Power System of PEFP

- 154kV Substation
- 3.3kV Switchgear
- Power Distribution System
(480V L/C, MCC, 220V L/C, Emergency Diesel Generator, UPS/DC system)

■ Monitoring & Control system of Electric Power System is designed.

- Protective device/Protection logic is designed for each power system component