

AN AUTOMATED INJECTION SYSTEM FOR ‘FILL ON FILL’ OPERATION

J. Trehwella, M. ten Have, D. McGilvery, Australian Synchrotron, Clayton, Victoria 3168, Australia

Abstract

The injection system for the Australian Synchrotron consists of a 100MeV linac and full energy (3GeV) booster, and requires the control of several hundred parameters to obtain good injection efficiency and minimise radiation. Previous machine procedures required operators to manually tune systems, and follow rigorous start up and shut down procedures. As a result, there were a number of beam loss events through failure to follow procedures and the efficiencies obtained varied significantly between operators.

An almost fully automated software layer, integrated with the EPICS control system, has been developed which optimises the sequence and timing of each individual sub system; virtually eliminating operator error, maintaining consistently high efficiency, minimising the run time of critical systems, reducing radiation levels and saving energy. It has also significantly reduced total injection time and stress levels for the operators. This system will be discussed, and will also include reviews of further benefits of semi-automated recovery after unscheduled beam loss events and progression to ‘top-up’ mode of operation.

BACKGROUND

In only the fourth year of operations, standard machine operating procedures have always been changing and updating. One such area that required attention was the injection procedures. Numerous rigorous manual procedures needed to be sequentially performed in order to inject. These procedures amounted to lengthy delays in injections, and varying Operator training levels also added inefficiencies between injections and in some cases caused beam loss events. Since operations began in April 2007, there have been 7 unscheduled beam losses caused by Operator error [1]. These could have been avoided by simply following the correct procedures.

In order to eliminate the human factor in performing a standard ‘fill on fill’ injection, an almost fully automated software layer needed to be developed. By utilising the already implemented EPICS control system framework, each manual procedure could be programmed to run in a sequencer programme. This would simply replicate the Operators procedures for an injection into a script.

AUTOINJECT FRAMEWORK

In order to have an almost fully integrated automation software system for injections, a standalone software layer was created called ‘Autoinject’. This was structured

on the accelerator network and utilising EPICS, was able to control all systems required for injections. Autoinject was designed and programmed in-house by the Operators. This was important as it enabled precise programming of the software to meet the stringent requirements. It would also benefit in the ease for any future updating purposes.

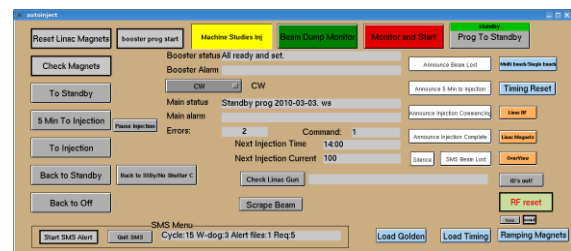

Figure 1: EDM Autoinject GUI interface

The code is programmed in C++ and consists of numerous sub routines that are utilised by an EDM GUI interface (Figure 1). These are both channel access (CA) clients and use CA protocols across the Accelerator LAN. Illustrated in Figure 2 is a schematic diagram of the control systems framework for Autoinject. EPICS PV's located on CA host IOC-21, are accessed over CA protocols from the C++ code and EDM GUI. This then communicates to other required PV's, IOC's and their corresponding systems.

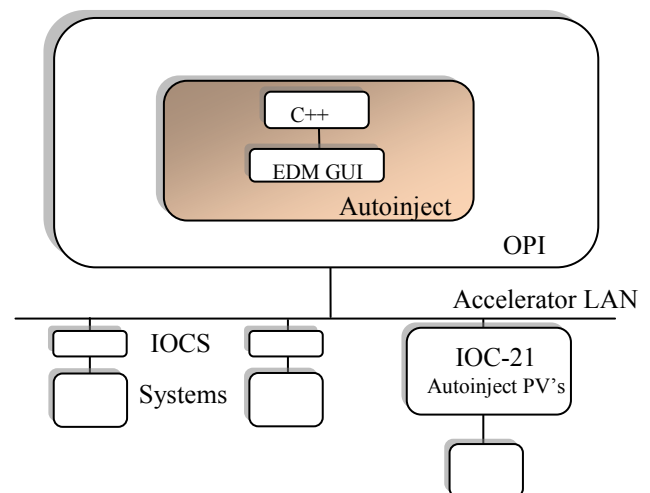

Figure 2: Schematic of control system for Autoinject

AUTOINJECT FUNCTIONALITY

There are numerous functions of Autoinject, but the initial design element was to automate 'fill on fill' injections during User beam. This was then incorporated with monitoring for unscheduled beam dumps, and an SMS notification system.

Automated 'fill on fill' injections

Currently we have to perform daily injections into the storage ring to 200mA every 12 hours. By utilising the programme, we have reduced the length of injections from ~10mins to ~4 minutes (*Figure 4*). This improvement has also had an impact on the injection time after beam losses, which reduces the overall down time of the fault.

Automated monitoring and start-up

To reduce the amount of recovery time in warming up the injection system elements after an unscheduled beam loss, we have designed and implemented an automated monitoring and start-up programme in Autoinject. By utilising the existing EPICS framework, the programme will constantly monitor the stored beam status and start warm-up procedures in the event of a beam loss. This has reduced the recovery time significantly and enabled standardised /repeatable recovery procedures.

SMS and PA automated notification system

Another software automation implemented is an SMS notification system (*Figure 3*). This is linked into the monitoring programme. When an unscheduled beam loss is detected by Autoinject, an immediate beam loss SMS message is sent to appropriate parties and a PA announcement is sent over the facility speaker system. This has allowed immediate recovery response to these events for Operators and technical staff. This has added to the reduction in down time for each associated fault occurrence.

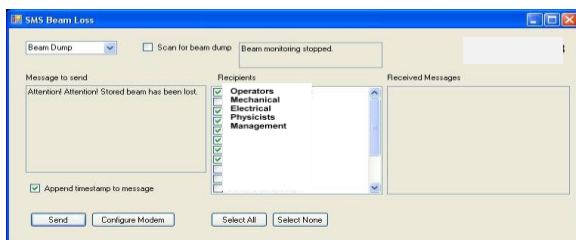

Figure 3: SMS notification system

AUTOINJECT IMPLEMENTATION RESULTS

As a result of the success of Autoinject, we can now discuss some of the results seen in comparison to before the system was implemented (Autoinject was implemented in June 2008).

Injection duration comparison

Figure 4 displays the impact that Autoinject has had on the injection duration. By automating this procedure we have reduced the average injection duration by ~61% (*Table 1*). This is important because it has:

- Reduced Operator input, which has virtually eliminated errors occurring during injections.
- Minimised the run time of critical systems, which increases their shelf life and saves on energy.
- Reduced the injection time during unscheduled beam dumps, which increases availability and reduces the mean down time of faults.

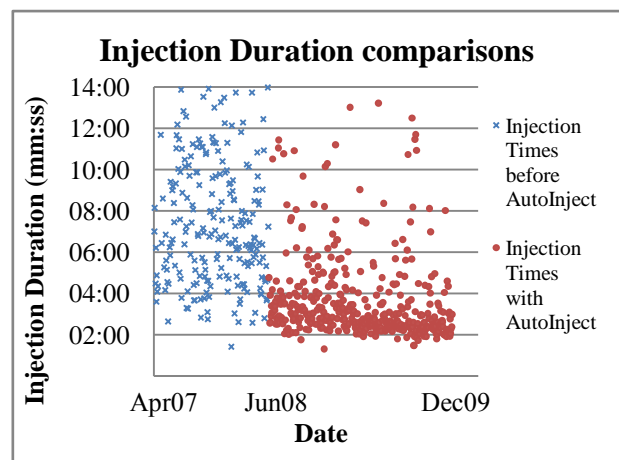

Figure 4: Injection Duration comparisons Plot [2]

Injection efficiency comparison

Another area that has impacted from the implementation of Autoinject, is the injection efficiency rate (*Figure 5*). The efficiency rate is a measure of the effective capture of injected electrons from the booster synchrotron to the storage ring, expressed as a percentage. Autoinject has increased the average efficiency rate by ~28% (*Table 1*). This was made achievable by turning on critical elements at specific times and ensuring those elements were stable before the injection commenced. Maximising our injection efficiency is important because:

- The higher our injection efficiency, the quicker we are injecting hence reducing our injection duration.
- Also, the higher the efficiency, the lower the losses in captured electrons, which decreases the radiation produced.

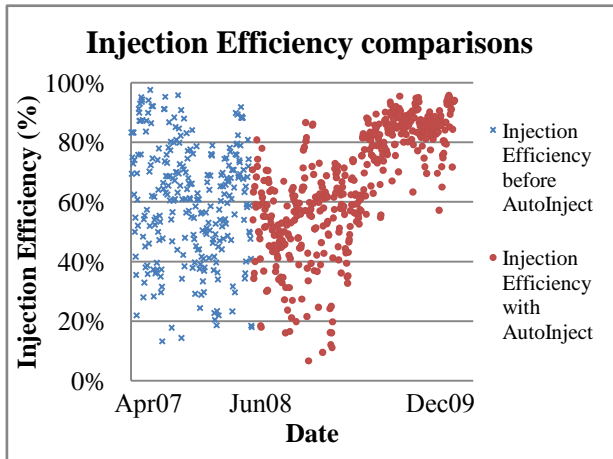

Figure 5: Injection Efficiency comparisons Plot [2]

Injection radiation dose comparison

By increasing the injection efficiency, Autoinject has effectively reduced the radiation losses during injection times (*Figure 6*). This has had the most dramatic impact, reducing the average radiation dose by ~ 93% (*Table 1*). One of the key responsibilities of an Accelerator Operator is radiation safety. It is pertinent that we minimise the amount of radiation produced as much as reasonably possible. So utilising a tool such as Autoinject is invaluable to the roles and responsibilities of an Operator.

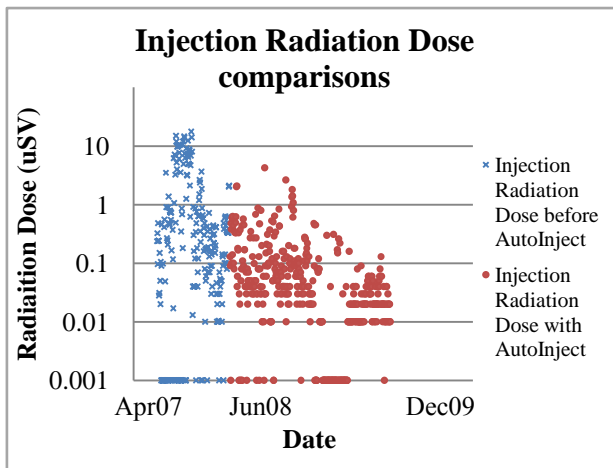

Figure 6: Injection Radiation Dose comparisons Plot [2]

COMPARISONS FOR AUTOINJECT

Table 1: Statistics before and after Autoinject [2]

| | Before Autoinject | After Autoinject | Percentage difference |
|---|-------------------|------------------|-----------------------|
| Average Injection Duration (mm:ss) | 10:32 | 04:05 | -61.18% |
| Average Injection Efficiency | 61.21% | 78.36% | +28.03% |
| Average Injection Radiation Dose (μSv) | 1.78 | 0.12 | -93.38% |

FUTURE DEVELOPMENTS

It is clear that a tool like Autoinject has dramatically improved numerous areas. Future development in other areas will also add to the improvements. The next stage of Operations at the Australian Synchrotron is the progression to Top-up mode. This will require extensive, systematic procedures to ensure successful operation. By utilising the already successful implementation of Autoinject, we will be able to adapt its functionality to the requirements of reaching Top-up mode.

CONCLUSIONS

- By automating rigorous Operator procedures, we have increased Operator and Machine efficiency across numerous areas.
- By successfully improving and implementing automated preventative measures and recovery procedures after an unscheduled beam loss, the Australian Synchrotron has improved in reliability.
- In only our fourth year of operations, the Australian Synchrotron has been achieving beam availability >98% [1]. This can be attributed to some of the successful implementations of Autoinject.
- As we grow into the future, hopefully the processes we have developed to resolving issues will help us maintain this successfully high availability.

REFERENCES

- [1] J. Trehwella, "Australian Synchrotron Operating Statistics Apr 2007 – Apr 2010".
- [2] J. Trehwella, "Reliability issues at the Australian Synchrotron: Preventative measures and recovery procedures", ARW'09, Vancouver, January 2009.